



St Norbert College

11 ATAR PHYSICS

Unit 1 – Linear Motion & Forces

Task 5: Topic Test

Assessment type: Tests and Examinations
Year weighting: 6%

Student name:	
TOTAL	/ 50

Time allowed for this paper

Working time for paper: fifty (50) minutes

Materials required/recommended for this paper

To be provided by the supervisor

This Question/Answer Booklet
Formulae and Data Booklet

To be provided by the candidate

Standard items: pens (blue/black preferred), pencils (including coloured), sharpener, correction tape/fluid, eraser, ruler, highlighters
Special items: non-programmable calculators approved for use in the WACE examinations, drawing templates, drawing compass and protractor

Important note to candidates

No other items may be taken into the examination room. It is **your** responsibility to ensure that you do not have any unauthorised notes or other items of a non-personal nature in the examination room. If you have any unauthorised material with you, hand it to the supervisor **before** reading any further.

Question 1

(7 marks)

In a rowing event a boat moves off in a straight line.



(a) A graph for the boat's motion is shown.

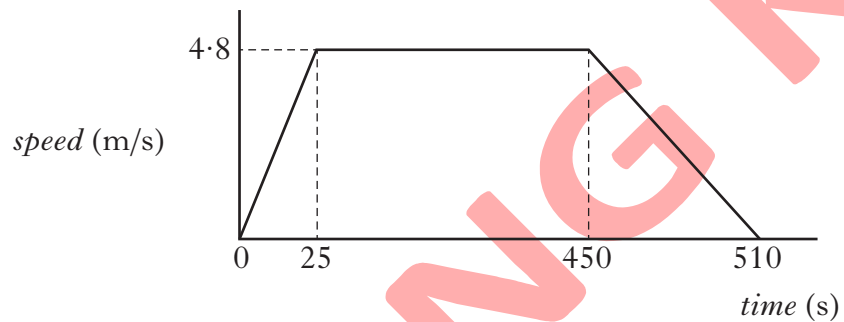

(i) Calculate the acceleration of the boat during the first 25 s.

(2 marks)

(a)	(i)	$a = (v - u) / t$	(½)
		$= (4.8 - 0) / 25$	(½)
		$= 0.192 \text{ m/s}^2$	(1)

(ii) Describe the motion of the boat between 25 s and 450 s.

(1 mark)

Constant speed

(b) The boat comes to a rest after 510 s.

(i) Calculate the total distance travelled by the boat.

(2 marks)

(i)	distance = a.u.g	(½)
	= (½ × 25 × 4·8) + (4·8 × 425)	
	+ (½ × 60 × 4·8)	(½)
	= 2244 m	(1)

(ii) Calculate the average speed of the boat.

(2 marks)

(ii)	$v = \text{total distance} / \text{time}$		
-------------	---	--	--

consistent with (b) (i)

2

OR

	= total a.u.g. / time	(½)
	= 2244 / 510	(½)
	= 4·4 m/s	(1)

Question 2

(6 mark)

A diver of height 1.80 m has his centre of gravity (C of G) 1.00 m above his feet when standing on the springboard. Fig. 1.1 illustrates the diver leaving the springboard, moving upwards and then entering the water.

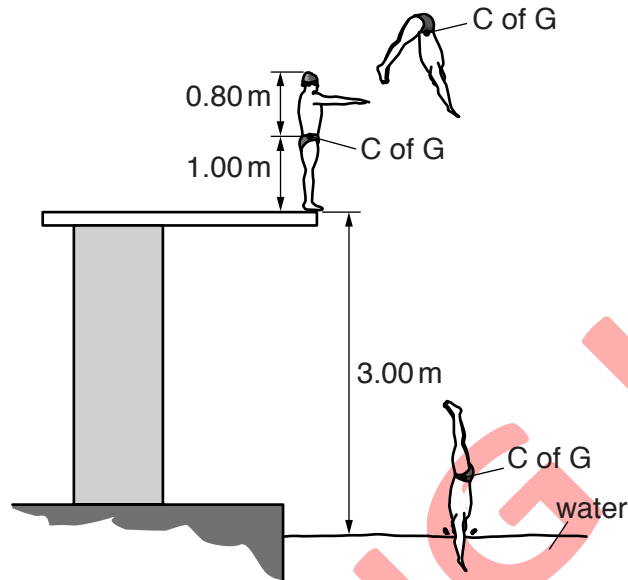

Fig. 1.1 (not to scale)

The diver leaves the springboard with an upward velocity of 5.6 m s^{-1} . The take-off point on the board is 3.00 m above the water.

Assume that the centre of gravity (C of G) of the diver remains at the same position within the diver throughout the dive and ignore air resistance.

- (a) Determine the maximum height of his centre of gravity above the water. (2 marks)

(a) $0 = 5.6^2 - 2 \times 9.81 \times s$ or $s = 1.60 \text{ (m)}$
 5.6 (m)

See next page

- (b) Determine the speed at which the diver's head reaches the water. (2 marks)

(b) $2 \times 9.8 \times (5.6 - 0.8)$ or $\sqrt{2 \times 9.81 \times 4.8}$
9.7 (ms⁻¹)

- (c) Determine the time the diver is in the air, between leaving the springboard and his head reaching the water. (2 marks)

(c) $9.7 = -5.6 + (9.81 \times t)$ or $t = 15.3/9.81$
1.56 (s)

Question 3

(7 marks)

- (a) Fig. 2.1 shows a jet aircraft preparing for take-off along a horizontal runway. The engine of the jet is running but the brakes are applied. The jet is not yet moving.

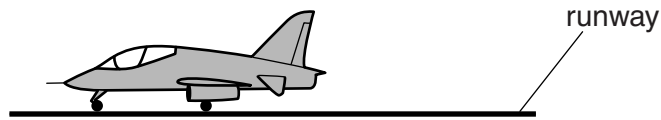
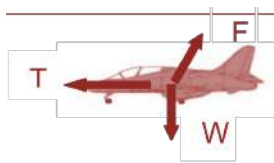

Fig. 2.1

On Fig. 2.1 draw an arrow to show each of the following forces acting on the jet: (2 marks)



Correct direction and labelling for W and T

Straight line for F

Correct direction **not** horizontal or vertical

- (i) the weight of the jet (label this W)
 (ii) the force produced by the engine (label this T)
 (iii) the total force exerted by the runway on the jet (label this F).
- (b) The brakes are released. The maximum force produced by the engine is 28 kN. The take-off speed of the jet is 56 m s^{-1} . The mass of the jet is 6200 kg.
- (i) Calculate the minimum distance the jet travels from rest to the point where it takes off. (3 marks)

$$a = T/m$$

$$a = 28 \times 10^3 / 6200 (= 4.516)$$

$$v^2 = u^2 + 2as$$

$$56^2 = 0 + 2 \times 4.516s \quad (\text{any subject})$$

$$s = 350 \text{ (m)}$$

C1

C1

A1

347 m

- (ii) Explain why the runway needs to be longer than the distance calculated in (i). (2 marks)

Air resistance/drag/friction acts on aircraft decreasing either the net forward force or the acceleration

M1

$Fs = \Delta KE$ so reduced force must act over a longer distance to produce enough kinetic energy for take-off

A1

OR

$v^2 = (u^2) + 2as$ so reduced acceleration means longer distance to reach take-off speed.

Question 4

(10 marks)

A simple pendulum consists of a bob of mass 1.8 kg attached to a string of length 2.3 m. The pendulum is held at an angle of 30° from the vertical by a light horizontal string attached to a wall, as shown below.

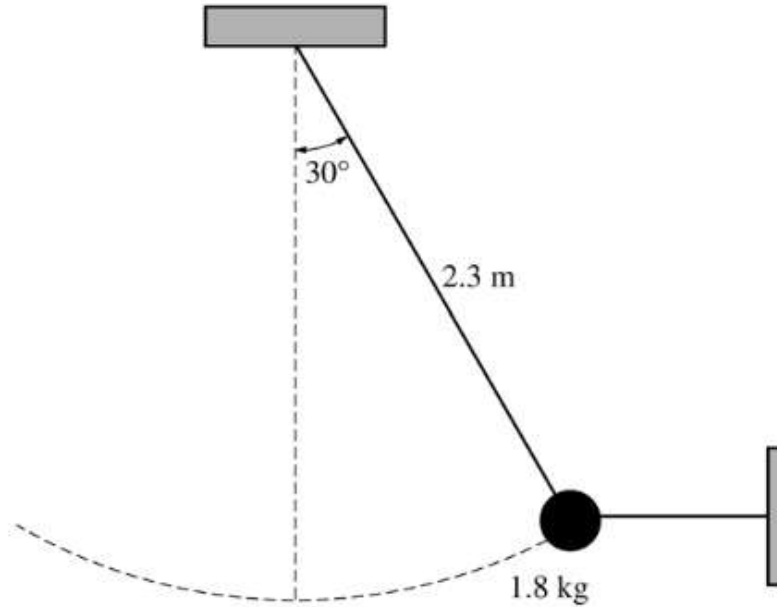

- (a) On the figure below, draw a free-body diagram showing and labelling the forces on the bob in the position shown above. (2 marks)

2 points

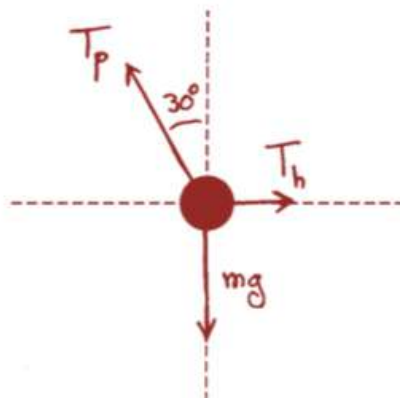

For each correctly drawn and labeled tension, with arrowhead in right direction
One point was deducted for each of the following until score reached zero:

- No force of gravity
 - Each extraneous force
 - Any missing labels
- Drawing all forces along correct lines with labels but no arrowheads received only one point.

Components of the tension in the pendulum string could be included in addition to or instead of the net tension, as long as they were clearly labeled as such.

1 point each

- (b) Calculate the tension in the horizontal string. (4 marks)

4 points

For any indication that the net force is zero 1 point

For an attempt to determine the components of the tension in the pendulum string 1 point

For correctly determining these components 1 point

$$T_h = T_p \sin 30^\circ$$

$$mg = T_p \cos 30^\circ$$

$$\frac{T_h}{mg} = \frac{\sin 30^\circ}{\cos 30^\circ} = \tan 30^\circ$$

$$T_h = mg \tan 30^\circ$$

$$T_h = (1.8 \text{ kg})(9.8 \text{ m/s}^2) \tan 30^\circ$$

For the correct answer with units 1 point

$$T_h = 10 \text{ N}$$

- (c) The horizontal string is now cut close to the bob, and the pendulum swings down. Calculate the speed of the bob at its lowest position. (4 marks)

4 points

For any indication of conservation of energy 1 point

For any indication of the need to use a change in height 1 point

$$mgh_0 + \frac{1}{2}mv_0^2 = mgh_f + \frac{1}{2}mv_f^2$$

For setting $v_0 = 0$ 1 point

$$\frac{1}{2}mv_f^2 = mg \Delta h$$

$$v_f = \sqrt{2g \Delta h}$$

$$\Delta h = L - L \cos 30^\circ$$

$$v_f = \sqrt{2gL(1 - \cos 30^\circ)}$$

$$v_f = \sqrt{2(9.8 \text{ m/s}^2)(2.3 \text{ m})(1 - \cos 30^\circ)}$$

For the correct answer, with units 1 point

$$v_f = 2.5 \text{ m/s}$$

A solution that used the kinematic equation $v_f^2 = v_0^2 + 2as$ could only receive full credit if the student explained how the equation is equivalent to conservation of energy.

Question 5

(5 marks)

An experiment is set up to investigate the motion of a cart as it collides with a force sensor.

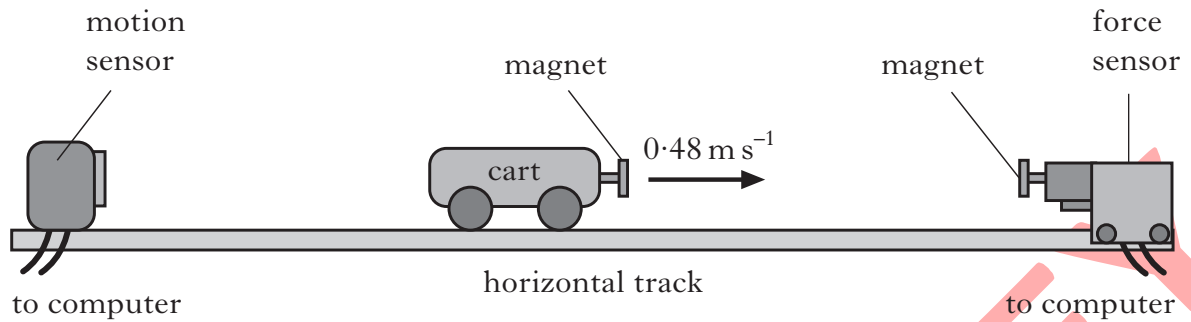

The cart moves along the horizontal track at 0.48 m s^{-1} to the right. As the cart approaches the force sensor, the magnets repel each other and exert a force on the cart. The computer attached to the force sensor displays the following force-time graph for this collision.

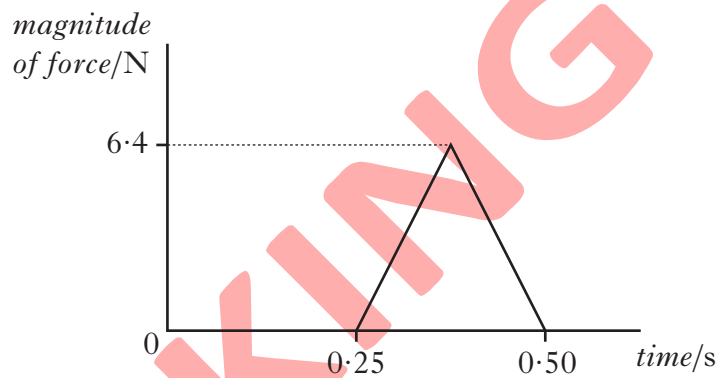

The computer attached to the motion sensor displays the following velocity-time graph for the cart.

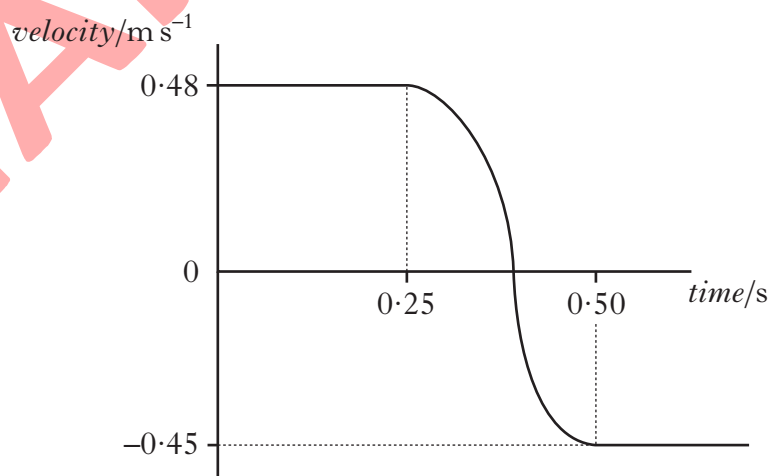

See next page

- (a) Calculate the magnitude of the impulse on the cart during the collision. (2 marks)

$$\begin{aligned}
 \text{(i) } \textit{Impulse} &= \textit{Area under } F\text{-}t \textit{ graph} && \frac{1}{2} \\
 &= \frac{1}{2} \times 6.4 \times 0.25 && \frac{1}{2} \\
 &= \mathbf{0.80} \text{ kg m s}^{-1} && 1
 \end{aligned}$$

- (b) Determine the magnitude and direction of the change in momentum of the cart. (1 mark)

$$\begin{array}{l}
 \mathbf{0.80} \text{ kg m s}^{-1} \\
 \text{in the negative direction} \\
 \text{OR to the left} \\
 \text{OR negative sign}
 \end{array}
 \left. \vphantom{\begin{array}{l} \mathbf{0.80} \text{ kg m s}^{-1} \\ \text{in the negative direction} \\ \text{OR to the left} \\ \text{OR negative sign} \end{array}} \right\}
 \begin{array}{l}
 \frac{1}{2} \\
 \frac{1}{2}
 \end{array}$$

- (c) Calculate the mass of the cart. (2 marks)

$$\begin{aligned}
 (\textit{Impulse} &= \textit{Change in momentum}) \\
 F \times t &= mv - mu && \frac{1}{2} \\
 -0.80 &= m(-0.45 - 0.48) && \frac{1}{2} \\
 m &= \mathbf{0.86} \text{ kg} && 1
 \end{aligned}$$

Question 6

(4 marks)

Two balls X and Y, are supported by long strings. This is shown in the figure below.

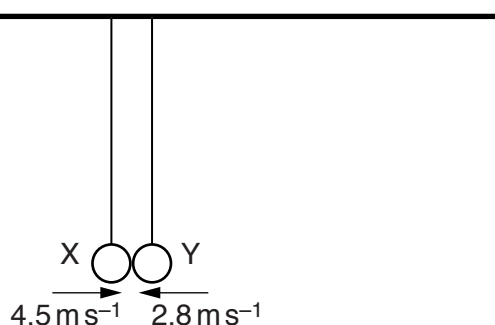

The balls are each pulled back and pushed towards each other. When the balls collide at the position shown in Fig. 3.1, the strings are vertical. The balls rebound in opposite directions.

The table below shows data for X and Y during this collision.

ball	mass	velocity just before collision/ ms^{-1}	velocity just after collision/ ms^{-1}
X	50g	+4.5	-1.8
Y	M	-2.8	+1.4

The positive direction is horizontal and to the right.

- (a) Use the conservation of linear momentum to determine the mass M of Y. (3 marks)

(a) $4.5 \times 50 - 2.8 \times M (= \dots)$

C1

$(\dots) = -1.8 \times 50 + 1.4 \times M$

C1

$(M =) 75\text{g}$

A1 [3]

- (b) State and explain whether the collision is elastic. (1 mark)

$\Sigma E_{k \text{ initial}} \neq \Sigma E_{k \text{ final}}$

Not elastic

Question 7

(11 marks)

A car is travelling along a road that has a uniform downhill gradient, as shown in Fig. 2.1.

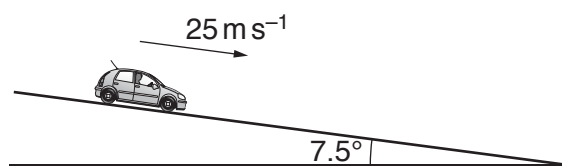

Fig. 2.1

- (a) The car has a total mass of 850 kg. The angle of the road to the horizontal is 7.5°. Calculate the component of the weight of the car down (parallel to) the slope. (2 marks)

$$\begin{aligned} \text{component of weight} &= 850 \times 9.81 \times \sin 7.5^\circ \\ &= 1090 \text{ N} \end{aligned}$$

(use of incorrect trigonometric function, 0/2)

C1
A1 [2]

- (b) The car in (a) is travelling at a constant speed of 25 m s⁻¹. The driver then applies the brakes to stop the car. The constant force resisting the motion of the car is 4600 N.

- (i) Show that the deceleration of the car with the brakes applied is 4.1 m s⁻². (2 marks)

$$\begin{aligned} \text{(i)} \quad \Sigma F &= 4600 - 1090 = (3510) \\ \text{deceleration} &= 3510 / 850 \\ &= 4.1 \text{ m s}^{-2} \end{aligned}$$

M1
A1
A0 [2]

- (ii) Calculate the distance the car travels from when the brakes are applied until the car comes to rest. (2 marks)

$$\begin{aligned} \text{(ii)} \quad v^2 &= u^2 + 2as \\ 0 &= 25^2 + 2 \times -4.1 \times s \\ s &= 625 / 8.2 \\ &= 76 \text{ m} \end{aligned}$$

C1
A1 [2]

(allow full credit for calculation of time (6.05 s) & then s)

- (iii) Calculate the loss of kinetic energy of the car. (2 marks)

1. kinetic energy = $\frac{1}{2}mv^2$
= $0.5 \times 850 \times 25^2$
= 2.7×10^5 J

C1

A1 [2]

- (iv) the work done by the resisting force of 4600 N. (2 marks)

work done = 4600×75.7
= 3.5×10^5 J

A1 [1]

- (v) The quantities in (iii) and in (iv) are not equal. Explain why these two quantities are not equal. (1 mark)

Difference is the loss in potential energy
